

Boomer S1

Single-boom face drilling rig for small drifts and tunnels with cross sections up to 33 m²

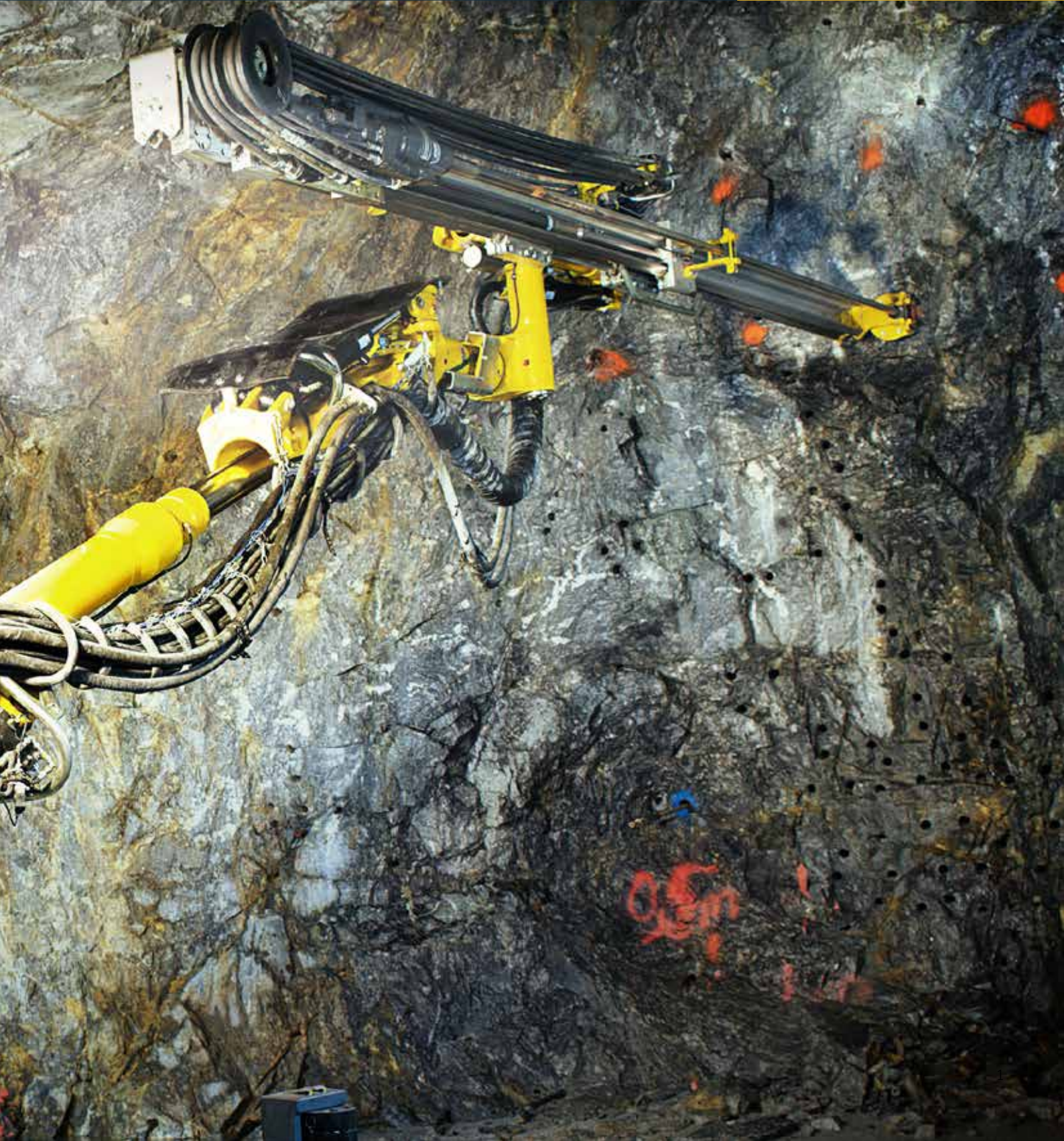

Groundbreaking productive drilling

The Boomer S1 is a face drilling rig for mining and tunneling with a heavy-duty boom that copes well with high loads to help you achieve desired advance rates. The boom features a double tripod setup that enables fast, precise positioning and accurate hydraulic parallel holding in all directions.

+ Main benefits

Safety and control thanks to a FOPS certified telescopic protective roof or an ergonomically designed ROPS and FOPS certified cabin which ensures safety and excellent visibility and surveillance for the operator

Outstanding drill steel economy with rock drills that feature dual damping for productive, high-speed drilling and great drill steel longevity

Large work radius thanks to a reel with a total of 70 meters of water hose and a longer electrical cable for an extensive work radius

ROPS and FOPS certified cabin



Safe and comfortable operator environment.



Excellence in drill steel economy and productivity.



Boomer S1 can cover a large work area thanks to 70 meters of water hose and extended electrical cable.

COP 1800HD+ series rock drills with 600 hrs service interval gives low operating costs

Light weight heavy duty aluminum feed for fast and precise positioning between holes



Boom with a double tripod setup that enables fast and precise positioning

A cutting-edge rig for drifting and tunneling

The robust Boomer S is ideal for tunnels with cross sections up to 33 m² and is equipped with a heavy duty feed for maximum durability. The drilling system incorporates rotation pressure controlled feed and an anti-jamming function for better drill steel economy and greater productivity.



+ Certified power and performance

The rig is powered by a 4-cylinder diesel engine that concurrently offers powerful performance and low emissions to reduce environmental impact. Engines are available with stage II, IIIA and IIIB certification to comply with emission standards in different markets. The diesel-driven hydraulic power source on the Boomer S1 D and S1 DH model provides outstanding flexibility; the diesel motor is used for both tramming and drilling.



+ Easy to operate and maintain

The operator enjoys an ergonomically designed cabin with a user-friendly interface to easily monitor and control all functions of the rig. With easy access to organized information, workflow is optimal. The rig is cleverly designed to provide straightforward access to all service points for easy maintenance.



+ The cop 1800HD+ series

Rock drills in the COP 1800HD+ series provide a sturdy four head bolt design, as well as a separate lubrication of driver and gear as well as pressurized side bolts and mating surfaces for reliable operation, low maintenance costs and long intervals between overhauls. The variable and reversible stepless rotation motor ensures high torque with exceptional speed control.



A comprehensive service offering

Even the best equipment needs to be serviced regularly to make sure it sustains peak performance. An Epiroc service solution offers peace of mind, maximizing availability and performance throughout the lifetime of your equipment. We focus on safety, productivity and reliability.

By combining genuine parts and an Epiroc service from our certified technicians, we safeguard your productivity – wherever you are.

Technical specifications

● - Standard ○ - Option
A = Boomer S1 B = Boomer S1 DH

Drilling system	A	B	Electrical system	A	B
COP 1638HD+	○	○	Total installed power 59 kW* (main motors 1x55 kW)	●	
COP 1838HD+	○	○	Total installed power 79 kW* (main motors 1x75 kW)	○	
COP 2238HD+	○		Total installed power 99 kW (main motors 1x95 kW)	○	
Water mist flushing, external water and air supply (water or air oil cooler)	○		Voltage 380-1 000 V	●	
Water mist flushing, internal air and external water	○		Frequency 50 Hz or 60 Hz	○	
Internal water mist flushing system with 250 l water tank	○		Starting method star/delta 380-690 V, direct start 1000 V	●	
Internal water mist flushing system with 560 l water tank		●	Starting method – soft start (not for 1000 V)	○	
Hole blowing kit	●	●	Transformer 5 kVA (4 kVA North America)	●	
Rock drill lubrication warning kit	●	●	Electronic overload protection for electric motors	●	
Big hole drilling system	●	●	Percussion hour meter	●	
Dry drilling system with dust collector	○		Digital volt/ampere meter in electrical cabinet	●	
Drill stop*	○	○	Phase sequence and eart fault indicator	●	
*Mandatory for CE			Battery charger	●	
			Dual controls for reels	●	
Boom	A	B	Electrical cable (Buflex)	○	
BUT 29	●	●	Connector	○	
Automatic boom lubrication kit (rear part of the boom)	●	○	Plug PC4/PC5	○	
Boom suspension system	○	○	Socket PC4/PC5	○	
			Switch gear	○	
			*Larger powerpacks may be used at high altitude or with certain options.		
Feed	A	B	Carrier	A	B
BMH 2825, drill steel length 2 500 mm			Deutz D914 L04, EPA III/COM III, Stage IIIA/Tier 3, 55 kW	●	
BMH 2831, drill steel length 3 090 mm	○	○	Deutz TCD 2012 L06, EPA III/COM III, Stage IIIA/Tier 3, 128 kW		●
BMH 2837, drill steel length 3 700 mm	○	○	Deutz TD 3.6 L04, Stage V, 55 kW	○	
BMH 2840, drill steel length 4 000 mm	○	○	Deutz BF4L 914, Tier II, 72 kW	○	
BMH 2843, drill steel length 4 310 mm	○	○	Deutz TCD 3.6 L04, CN4, 65 kW	○	
BMH 2849, drill steel length 4 920 mm	○	○	Articulated ±40° steering angle	●	●
Telescopic feed BMHT 2000-series (max 4.3 m)	○	○	Four wheel drive	●	●
Extension drilling set BSH 110 (BMH feeds only)	○	○	Electrical system 24 V	●	●
Bulk head style hose tree on feeds	○	○	Batteries 2x12 V, 70 Ah	●	●
Mining (heavy-duty) centralisers	○	○	Working lights, 4x80 W LED 24 V DC	●	
			Tramming lights, 4x40 W+2x80 W LED 24 V DC	●	
Air/water system	A	B	Illuminated stairs	○	○
Hydraulic water booster pump capacity at 12 bar, 66 l/m	●		Automatic differential lock on front axle	●	●
Compressor: Epiroc GAR30*	○	●	Tires, 9.00xR20	●	●
Compressor: Epiroc LE7	●		Clearance outside axles rear 15"	●	●
Water hose reel, including water hose	○		Front and rear hydraulic jacks	●	●
*When equipped with COP 1838 a 95 kW powerpack is required (Not for diesel hydraulic).			Fuel tank volume, 4 Cylinder engine: 60 l	●	
			Fuel tank volume, 6 cylinder engine: 160 l		●
Hydraulic system	A	B	Fire suppression system ANSUL (manual)	○	○
Low oil level indicator	●	●	Performance package		
Oil temperature meter	●	●	Manual lubrication kit	○	○
Filtration 16 µm	●	●	Rig washing kit		
Oil filter indicator	●	●	Comfort package		
Mineral hydraulic oil	●	●	Boot washing kit	○	
Electric oil filling pump	●	●	Cold weather package		
Water/oil cooler	●		Cold weather package		
Air/oil cooler	○	●	Hydraulic oil heater		
Hydraulic oil thermostat	●	●	1.2 kW heater (cabin)	○	○
Cold weather package			Main electric motor heater		
Heater for hydraulic oil tank	○	○	Diesel engine heater (water cooled engine, Stage 3B)		
Aggressive water package					
Ni-Cr plated piston rods (limitations exist)	○	○			
Control system	A	B			
Hydraulic pilot control system	●	●			
Feed Angle Measurement, FAM 1	○	○			
Feed Angle Measurement with hole depth, FAM 3	○				

Technical specifications

● - Standard ○ - Option
A - Boomer S1 **B** - Boomer S1 DH

Cabin (Optional)	A	B
ROPS and FOPS certified air conditioned cabin, noise level <80 dB(A)	●	●
Joystick controlled spot light, 70 W (left side)	●	○
Air condition, cooling only	●	●
12 V outlet	●	●
Comfort outlet		
Media player	○	○
Comfort outlet		
Swingable seat	○	○

Protective roof	A	B
12 V outlet	●	●
Comfort outlet		
Swingable seat for drilling and tramping	○	○
Comfort outlet		
Spotlight 70 W	○	○

Drill rods	Minimum hole diameter
R38-H35-R32	45 mm
R38-H35-SR35 Speedrod	45 mm
T38-H35-R32	45 mm
T38-H35-R32 Speedrod	45 mm
T38-H35-SR35	45 mm
T38-H35-R35	48 mm
T38-H35-R35 Speedrod	48 mm
T38-R39-R35	48 mm
T38-R39-SR35	45 mm
T38-R38-R35	48 mm

Extension rods for injection drilling/RAS	Minimum hole diameter
R32 Speedrod	51 mm
T38 Speedrod	64 mm

Shank adapters	Diameter	Length
R38	38 mm	435 mm
T38	38 mm	435 mm
R32	38 mm	525 mm
T38	38 mm	525 mm

Couplings	Diameter	Length
R38	55 mm	170 mm
T38	55 mm	190 mm

Recommended cable sizes and lengths (59kW)	Dimension, mm ²	Diameter, mm	Length, m
380-400 V	3x50+3G10+2x1.5	33	150
440 V	3x50+3G10+2x1.5	33	150
500-525 V	3x35+3G6+2x1.5	29	200
550-575 V	3x35+3G6+2x1.5	29	200
660-690 V	3x35+3G6+2x1.5	29	200
1 000 V	3x35+3G6+2x1.5	29	200

Recommended cable sizes and lengths (79 kW)	Dimension, mm ²	Diameter, mm	Length, m
380-400 V	3x70+3G16+2x1.5	39	110
440 V	3x70+3G16+2x1.5	39	110
500-525 V	3x70+3G16+2x1.5	39	110
550-575 V	3x50+3G10+2x1.5	33	150
660-690 V	3x35+3G6+2x1.5	29	200
1 000 V	3x35+3G6+2x1.5	29	200

Recommended cable sizes and lengths (99 kW)	Dimension, mm ²	Diameter, mm	Length, m
380-400 V	3x95+3G16+2x1.5	39	80
440 V	3x95+3G16+2x1.5	39	80
500-525 V	3x70+3G16+2x1.5	39	110
550-575 V	3x70+3G10+2x1.5	39	110
660-690 V	3x50+3G10+2x1.5	33	150
1 000 V	3x35+3G6+2x1.5	29	200

Dimensions	A	B
Width	1 750 mm	1 750 mm
Height, roof down	2 128 mm	2 168 mm
Height, roof up	2 828 mm	2 868 mm
Cabin height (Option)	2 800 mm	2 850 mm
Length, tramping	11 040 mm BMH 2843	11 040 mm BMH 2843
Ground clearance	365 mm	365 mm
Turning radius outer/inner (BMH2843)	4 950/2985	4 950/2985

Weight	A	B
Total	12 800 kg	12 850 kg*
Boom side	8 350 kg	8 150 kg
Engine side	4 500 kg	4 700 kg

*Empty water tank

Boomer S1 – noise and vibration	
Operator sound pressure level in cabin, drilling, free field (ISO 11201)	75±3 dB(A) re 20 uPa
Operator sound pressure level working close to machine, drilling, free field	103±6 dB(A) re 20 uPa
Sound power level (ISO 3747), drilling, free field	123 dB(A) re 1 pW
Peak C-weighted instantaneous sound pressure level (EN16228)	Less than 130 dB
Vibration levels seated, drilling (ISO 2631-1) cabin	0.07±0.07 m/s ²
Vibration levels seated, drilling (ISO 2631-1) canopy	0.15±0.15 m/s ²
Vibration levels standing, drilling (ISO 2631-1) cabin	0.07±0.07 m/s ²
Vibration levels standing, drilling (ISO 2631-1) canopy	0.15±0.15 m/s ²

Boomer S1 DH – noise and vibration	
Operator sound pressure level in cabin, drilling, free field (ISO 11201)	80±5 dB(A) re 20 uPa
Operator sound pressure level close to machine, drilling, free field	103±6 dB(A) re 20 uPa
Sound power level (ISO 3747), drilling, free field	123 dB(A) re 1 pW
Peak C-weighted instantaneous sound pressure level (EN16228)	Less than 130 dB
Vibration levels seated, drilling (ISO 2631-1)	0.07±0.07 m/s ²
Vibration levels standing, drilling (ISO 2631-1)	0.07±0.07 m/s ²

Technical specifications

Dimensions in millimeters

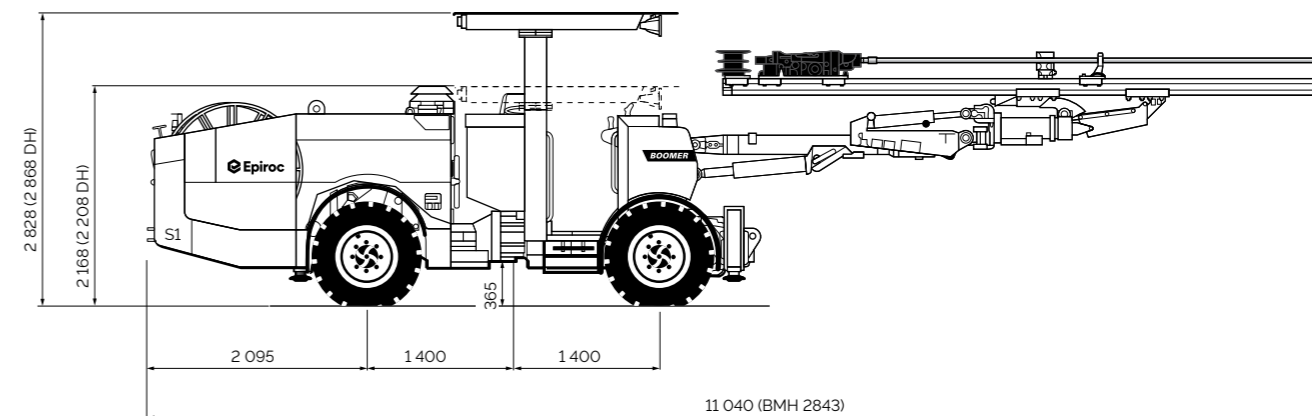

Dimension illustration (optional equipment mounted).

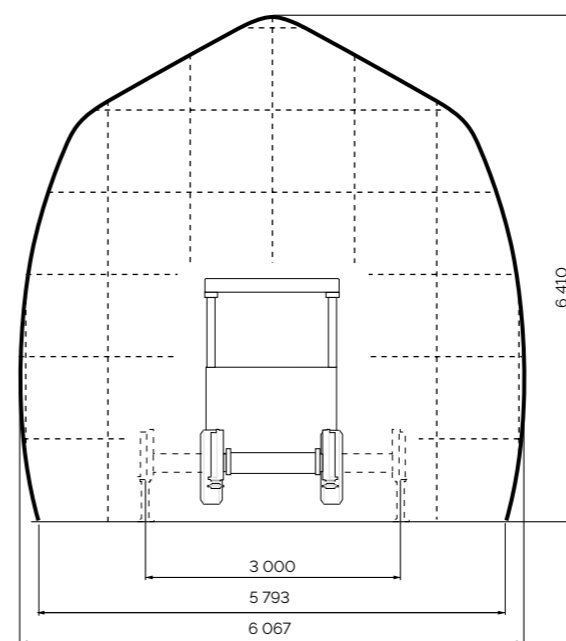

Coverage area 33 m².

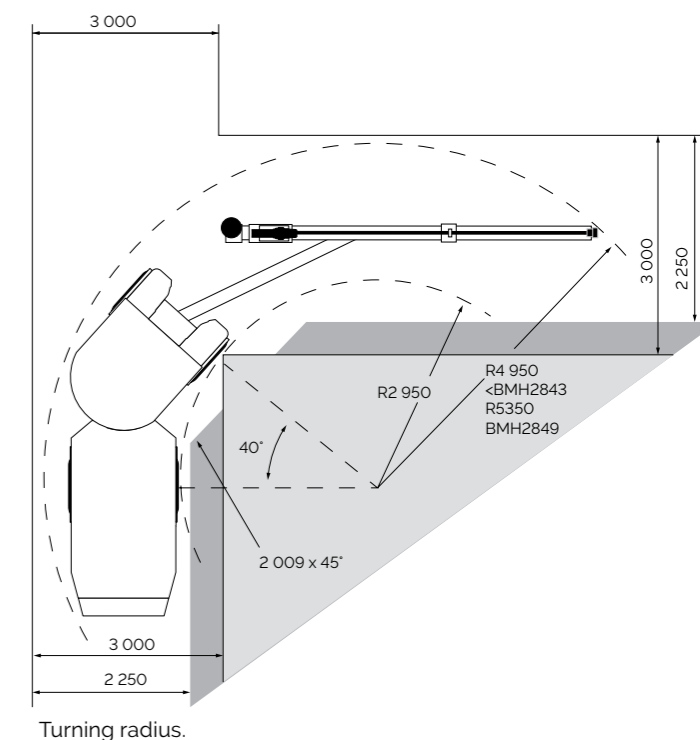

Turning radius.

9869.0094.01c.2022-02 Örebro, Sweden. Legal Notice © Copyright 2022, Epiroc Rock Drills AB, Örebro, Sweden. All product names in this publication are trademarks of Epiroc. Any unauthorized use or copying of the contents or any part thereof is prohibited. Illustrations and photos may show equipment with optional extras. No warranty is made regarding specifications or otherwise. Specifications and equipment are subject to change without notice. Consult your Epiroc Customer Center for specific information.



United in performance. Inspired by innovation.

Performance unites us, innovation inspires us, and commitment drives us to keep moving forward. Count on Epiroc to deliver the solutions you need to succeed today and the technology to lead tomorrow.
[epiroc.com](https://www.epiroc.com)

